

IF IN DOUBT ASK

| ISSUE | DESCRIPTION | T/O No. | DRAWN | DATE | APPROVED | DATE |
|-------|-------------------------------|---------|-------|--------|----------|------|
| A | RELEASE FOR CUSTOMER APPROVAL | tba | E.C | 5-5-15 | - | - |
| | | | | | | |
| | | | | | | |
| | | | | | | |

Top view

Scale: 1:10

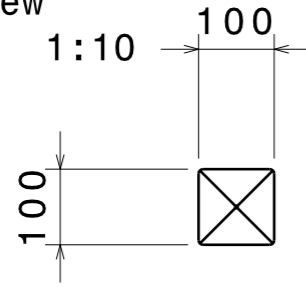

Left view
Scale: 1:10

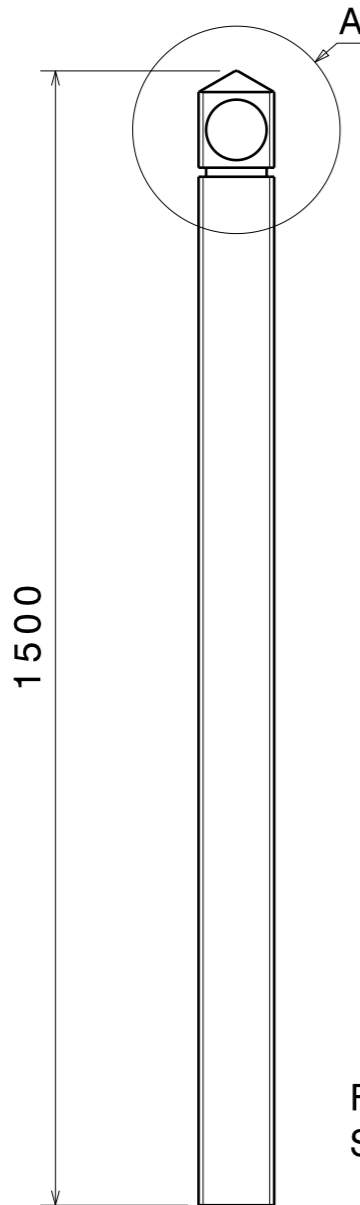

Front view
Scale: 1:10

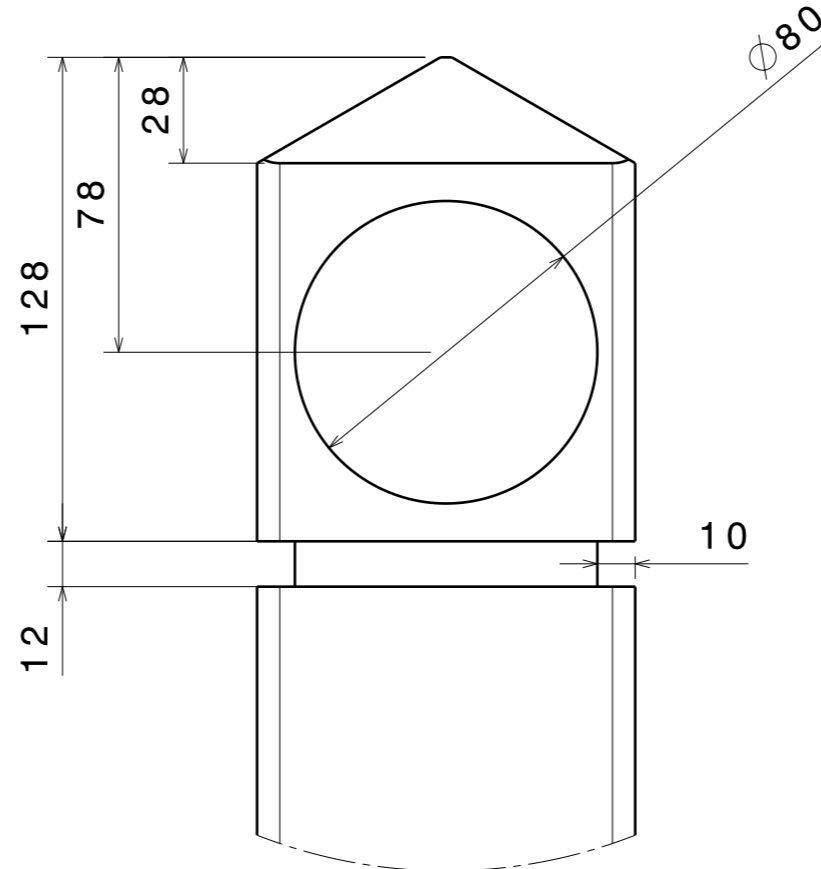

Detail A
Scale: 1:2

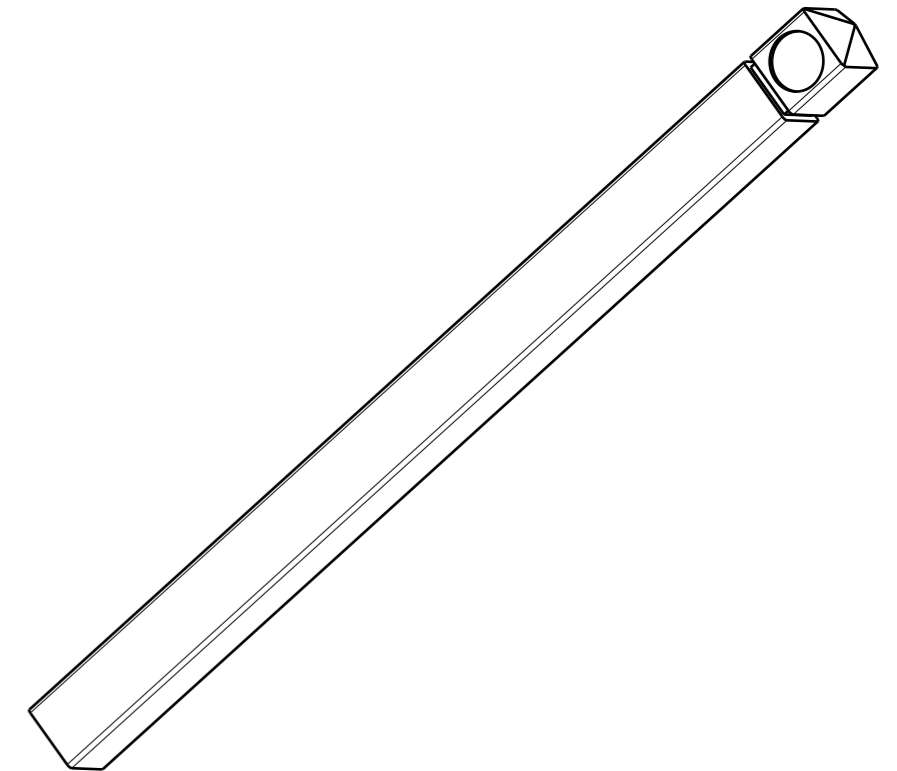

Isometric view
Scale: 1:10

RED REFLECTOR FITTED ONE SIDE
CLEAR REFLECTOR FITTED OTHER SIDE

QUALITY NOTE

STRAIGHTNESS

Product will have no more than a 1:50 bend

SWELLING

Product may have up to 5% swelling

SINK

Product may have up to 3% sinkage predominantly on the end cuts

SURFACE FINISH

Product may have small bumps on the exterior surface Each not exceeding 8mm diameter x 4mm high No more than 10 surface bumps per metre

LENGTH

Product may be up to 25mm longer than the specified length

VOIDS

Product may have small voids not exceeding 5mm. No more than 2 voids per section cut.

CORNER TEARING

There may be a small amount of corner tearing Each not exceeding 5mm wide x 2mm deep Not exceeding 4 aberrations per metre

Notice

This drawing was prepared by the staff of Advanced Plastic Recycling and the copyright therein belongs to the company. All rights conferred by the law of copyright and by virtue of international copyright conventions are reserved to the company. Reproduction requires the prior written consent of the company. As the drawing may incorporate confidential information of the company, its disclosure to others requires the company's prior written consent. Any infringement of this copyright may result in legal action.

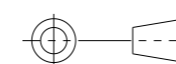

THIRD ANGLE
PROJECTION



Advanced Plastic Recycling,
9/500 Churchill Road
KILBURN SA 5084

TELEPHONE (08) 8359 4999
FACSIMILE (08) 8359 4988
A.B.N. 75 858 453 725

| | | | | | |
|--------------------------|-----|----------|------------|----------|--------------|
| DESIGNED | E.C | SCALE | AS SHOWN | MATERIAL | A.P.R.-W.P.C |
| DRAWN | E.C | © DATE | 05-05-2015 | TOOL No. | |
| CHECKED | K.C | APPROVED | C.L | SHEET | 1 OF 1 |
| PART NAME | | | | PART NO. | |
| 100X100 PEAK TOP BOLLARD | | | | 50515 | |